

TWISTER

ROOF VENTS 19' - 44' BINS INSTALLATION INSTRUCTIONS

1. Use the roof vent as a template to mark out the bolt holes.
2. Mark and cut a 15" diameter circle inside the bolt pattern (shaded area) as shown in Figure 1.

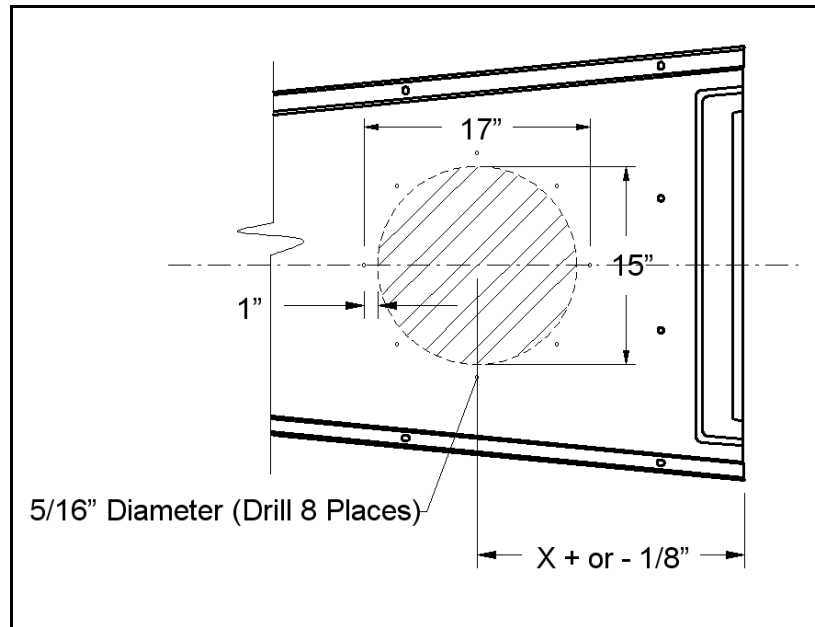

Figure 1 Roof Vent

BIN SIZE	X
19'	20"
22'	20"
25'	32 1/2"
32'	32 1/2"
38'	32 1/2"
44'	32 1/2"

3. Use solvent to remove mill oil for two inches outside the edge of the cut hole.
4. Place the 3/16" x 3/16" caulking on the outside bottom edge of the vent flange.
5. Bolt the vent flange to the roof sheet using 1-1/4" x 1" bolts and 1/4" flange nuts.

6. Confirm that you have a water tight seal by pouring water around the outer edge of the flange nuts. If there is any leakage, apply extra caulking.

Material List

1	Instruction Sheet
1	Roof Vent
8	1/4" x 1" Bolt
8	1/4" Flange Nut
1	Roll 3/16" x 3/16" x 7' Caulking

Part Number: BTA-11246

Revised: 19/3/08